

RT980

SPECIFICATIONS



GROVE MANUFACTURING COMPANY

Division of Walter Kidde & Company, Inc.

KIDDE

SHADY GROVE, PA. 17256



SUPERSTRUCTURE SPECIFICATIONS

BOOM — 36 ft. - 146 ft. (11.0m - 44.3m) total length; 4-section trapezoidal main boom consisting of base section and three full power sections to 114 ft. (34.6m) and a 32 ft. (9.8m) "swing-away" lattice boom extension to 146 ft. (44.3m). Power is supplied by three 6½ in. (165mm) diameter bore double-acting cylinders with integral holding valves. Boom telescope sections are supported on Nylatron wear pads. Side adjustable wear pads prevent metal-to-metal contact of inner boom sections and permit ease of boom side alignment.

LATTICE BOOM EXTENSION — Standard 32 ft. (9.8m) lattice "swingaway" boom extension stows alongside base boom section. Boom extension swings into position; attaches and is held to main boom nose with 4 corner pins. Single metallic 19½ in. (495mm) tread diameter sheave with removable, pin-type rope guard and rope dead-end.

***JIBS** — 28 ft. (8.5m) A-frame jib attaches to sheave shaft of the 32 ft. (9.8m) lattice "swingaway" boom extension. Jib stows beneath extension alongside base boom section, or can be detached from "swingaway" and held firmly in place on base section when extension is used independently. Jib can be offset at 5°, 15° and 30°. Includes jib backstops, single rope self-equalizing suspension and removable pin-type rope guard.

14 ft. (4.3m) lattice base section combines with the standard 32 ft. (9.7m) lattice "swingaway" boom extension to make basic 46 ft. (14.0m) jib. Additional 14 ft. (4.3m) pinned inserts available to make 60 ft. (18.3m), 74 ft. (22.6m) and 88 ft. (26.8m) jib lengths. Mast, pendant lines attaching hardware and backstops included in the makeup of all jib lengths. Jib sheave mounted on tapered roller bearings. The jib is cable suspended and can be offset at 5°, 17° and 30°.

BOOM NOSE — Reinforced hi-strength steel construction. Six metallic load bearing sheaves, 19½ in. (495mm) tread diameter, mounted on heavy duty tapered roller bearings. Two metallic floating idler sheaves 19½ in. (495mm) tread diameter mounted on bronze bushings. Removable pin-type rope guards for easy reeving. Rope dead ends on either side of the boom.

***AUXILIARY BOOM NOSE** — Removable single metallic sheave, 19½ in. (495mm) tread diameter, mounted to main boom nose for single part line work. Equipped with a removable pin-type rope guard.

BOOM ELEVATION — Dual 11 in. (279mm) diameter bore, double-acting hydraulic cylinders with integral holding valves. Elevation -4° to 80°, combination controls for hand or foot operation.

SWING — Grove planetary speed reducer powered by a hydraulic high torque, low RPM orbit motor providing smooth/precise 360° continuous rotation. Equipped with Grove "glide swing" with foot-activated multiple disc swing brake for precision stopping. Electric/hydraulic swing parking brake and hand-operated 360° positive swing lock controlled from operator's cab. Externally driven sealed gear bearing. Precision machined bearing mounting surface prevents distortion of swing circle hearing. Maximum speed 1.8 RPM.

CAB — Turntable-mounted. Fully enclosed, all steel with acoustical treatment. Full vision with tinted safety glass throughout, hinged skylight, sliding left side door and sliding right side window for ventilation. Dash-mounted control levers, combination hand and foot controls for boom elevation and engine throttle, outrigger sight leveling bubble, electronic boom angle indicator with high and low angle presets and A/V warning, electric windshield washer/wiper, steering wheel-mounted electric horn, door and window locks, domelight, dashlight, 2¼ lb. (1.3kg) dry-type fire extinguisher, cab mounted worklights, 20,000 BTU/Hr. diesel fuel heater, forced hot air defroster.

CONTROLS — Left of steering wheel are dash-mounted hand-operated control levers for swing, and boom-telescope; at right are control levers for rear steer, boom elevation, auxiliary hoist, main hoist and *free-fall control. Foot-operated controls include dynamic swing brake, boom elevation, service brakes and engine throttle. Operator's right hand console includes transmission gear selection, high-low range selector, hand throttle, outrigger controls, sight leveling bubble, heater controls, console panel lights, engine start/stop. Additional dash-mounted controls include electric manual oscillation lockout override, worklights, master ignition and rear steer alignment indicator.

CAB INSTRUMENTATION — International gauges. Engine water temperature, fuel level, oil pressure, air pressure, tachometer, transmission and torque converter oil temperature and pressure, A/V warning for low air system pressure, and parking brake indicator.

COUNTERWEIGHT — Removable, bolted to turntable mast, stationary. Weight varies dependent on hoist configuration. (Refer to Axle Weight Distribution Chart).

***LOAD MOMENT & ANTI-TWO BLOCK SYSTEM (KRUEGER)** - Audio-visual warning in combination with Grove control lever lockout of: hoist-up, telescope out and boom down crane functions. Krueger LMI control console provides operator with selective display of boom length, radius and angle. *A separate Grove anti-two block system can be obtained independent of the complete Krueger LMI, and is available with audio-visual warning only or audio-visual warning in combination with Grove control lever lockout of: hoist-up, telescope out and boom down crane functions.

*Denotes optional equipment

† Patented Grove feature or patent pending

HOIST SPECIFICATIONS

DESCRIPTION: Power up and down, equal speed, planetary reduction with integral automatic brake and electronic rotation indicators.

HOIST DATA	MAIN HOIST Grove Model HO30B-26	AUXILIARY HOIST Grove Model HO30B-16	*AUXILIARY HOIST Gearmatic Model 23 MGECR (Controlled Free Fall)		
Drum Dimensions	16 in. dia (406mm) 26 in. length (660mm) 24 in. flange dia. (610mm)	16 in. dia. (406mm) 16 in. length (406mm) 24 in. flange dia. (610mm)	14.5 in. dia. (368mm) 16 in. length (406mm) 22.3 in. flange dia. (568mm)		
Performance: Max. Single Line Speed	Hi-Speed Range 575 FPM (175m/min)	Lo-Speed Range 290 FPM (88m/min)	Hi-Speed Range 575 FPM (175m/min)	Lo-Speed Range 290 FPM (88m/min)	422 FPM (129m/min)
Max. Single Line Pull	8,400 lbs. (3810kg)	16,800 lbs. (7620kg)	8,400 lbs. (3810kg)	16,800 lbs. (7620kg)	11,700 lbs. (5307kg)
Drum Rope Storage Capacity	**1,060 ft. of ¾ in. dia. rope (323m of 19mm)	**650 ft. of ¾ in. dia. rope (198m of 19mm)	**700 ft. of ¾ in. dia. rope (213m of 16mm)		
Permissible Single Line Rope Pull	¾ in. (19mm) 18x19 class - 14,605 lbs. (6625kg)	¾ in. (19mm) 18x19 class - 14,605 lbs. (6625kg)	¾ in. (19mm) 18x19 class - 14,605 lbs. (6625kg)	5/8 in. (16mm) 18x19 class - 10,207 lbs. (4630kg)	

**Denotes optional equipment. Auxiliary hoist control valve is standard equipment.*

***6th layer of rope not recommended for hoisting operation (7th layer for Gearmatic Model 23 Auxiliary Hoist).*

THREE MODES OF THE GROVE RT980 SWINGAWAY/JIB COMBINATION –



The 32 ft. Swingaway and optional 28 ft. A-frame jib can provide the RT980 with an additional 60 ft. of reach capability, conveniently stowed on the crane. The three different modes of this combination are:

1. Lifting from the main boom with the Swingaway extension and jib stowed alongside the base boom section.

2. Lifting from the main boom or Swingaway with the Swingaway erected and the jib stowed alongside the base boom section.

3. Lifting from the main boom, Swingaway, or jib with both Swingaway and jib erected.

DIMENSIONS



TURNING RADIUS 23' (7010)
TAIL SWING 14' 3" (4343)

NOTE: Figures in parentheses () are metric equivalents expressed in millimeters.

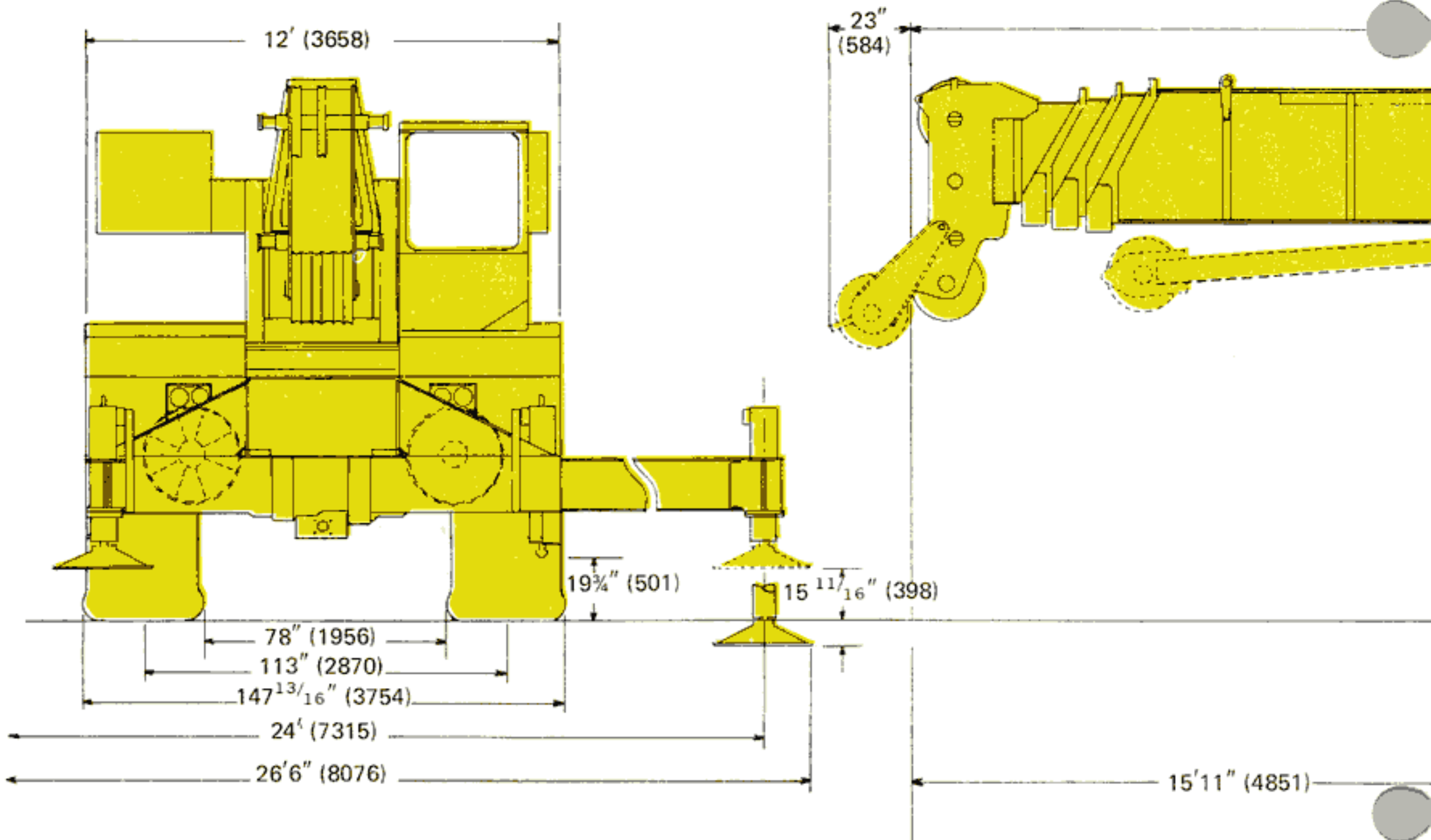

SPEED AND GRADEABILITY

Forward Drive	Transmission Range	Gear Shift	Maximum Speed		Gradeability @ Stall (%)	Tractive Effort at Stall	
			MPH	KM/H		LBS.	KG
4 Wheel Drive	Low	1st	1.4	2.3	81.9	84,942	38 530
4 Wheel Drive	Low	2nd	3.0	4.8	30.2	40,139	18 207
4 Wheel Drive	Low	3rd	7.6	12.2	9.4	14,715	6675
2 Wheel Drive	High	1st	4.0	6.4	20.9	29,168	13 231
2 Wheel Drive	High	2nd	8.0	12.9	8.6	13,796	6258
2 Wheel Drive	High	3rd	18.0	28.9	1.9	5,058	2294

NOTE: All performance data is based on standard machine and may vary plus or minus 10% due to variations in engine performance. Gradeability values above 45% are theoretical. Machines should be operated within the limits of engine crankcase design (30° - GM, 45° - Cat, 45° - Cummins).

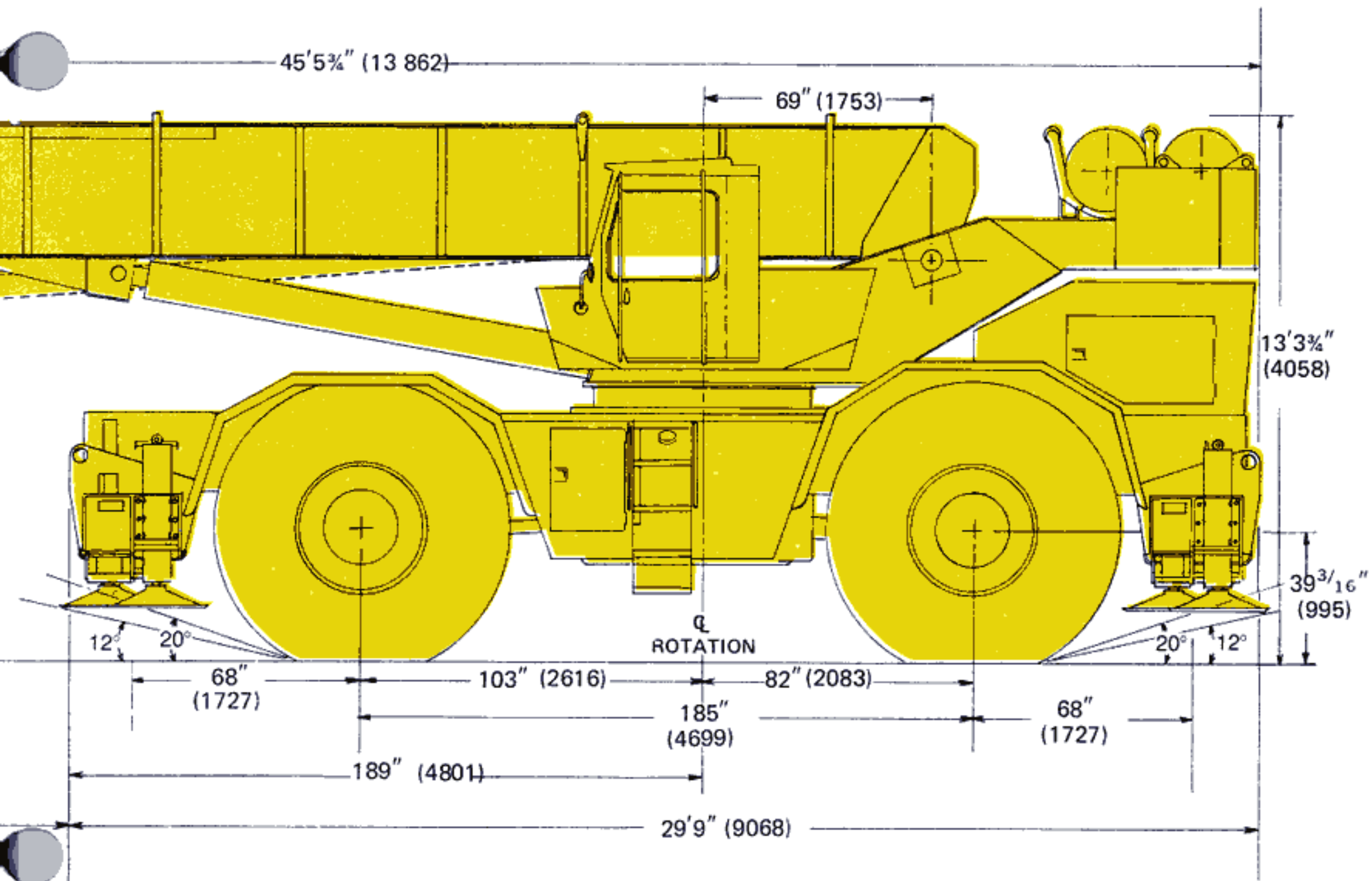



CHASSIS SPECIFICATIONS

MAIN FRAME — All welded double parallel box beam construction with boxed cross-members to the rear of the frame and triple box construction to the front of the frame reinforced at critical points to resist torsional stresses and provide a strong, rigid lifting base. Precision machined bearing mounting surface prevents distortion of swing bearing. Front and rear combination lifting/towing and tie-down lugs are integral with main frame.

OUTRIGGERS — Front and rear hydraulic double-box integral with main frame; telescoping beams extend to 24 ft. (7.3m) center-to-center and retract to 12 ft. (3.7m) by 3 in. (76mm) bore double-acting cylinders. 23½ in. (597mm) stroke 7 in. (177mm) bore double-acting vertical jacks with integral check valves for quick leveling on uneven terrain. Vertical jacks equipped with removable, stowable, lightweight, high strength 30 in. (762mm) diameter steel floats. All outrigger controls located in operator's cab. Required sequence control arrangement eliminates unintentional outrigger actuation. In addition to the standard integral holding valve and for added security, the exclusive Grove *spin-lock is offered which permits the outrigger vertical jack to be mechanically locked in any position throughout its stroke.

TRANSMISSION & TORQUE CONVERTER — Remote mounted full powershift transmission with six speeds forward and reverse with rear axle disconnect. Engine-mounted torque converter 2.16:1 stall ratio with PTO for hydraulic pumps.

SPEEDS — 6 forward and 6 reverse
(3 speeds - High range — 2-wheel drive)
(3 speeds - Low range — 4-wheel drive)

AXLES — Front: planetary drive/steer type mounted rigid to the frame. Total reduction ratio 32.07:1.

Rear: planetary drive/steer type mounted to allow 0 in. to 12 in. (305mm) oscillation for rough terrain negotiation. Total reduction ratio 32.07:1. Equipped with no-spin differential.

HYDRAULIC OSCILLATION LOCKOUT — Automatic, full hydraulic on rear axle. Permits rear axle oscillation only with boom over front. Rear axle lockout assures a rigid lifting platform when lifting on-rubber over-the-side. Manually-activated electric override control.

STEERING — Front — power assist hydraulic; controlled by steering wheel. Dual steering cylinders.

Rear — full hydraulic, tiller bar control. Dual steering cylinders. Independent front and rear steer control allows operator to choose mode of travel for optimum "on the move" maneuverability. Four modes available are: independent front wheel steer, independent rear wheel steer, 4-wheel coordinated steer and 4-wheel crab steer. *Electric emergency power steering system provides power steering in the event of engine failure by means of a direct current motor powered by the crane's starter battery and energized when the power steering system pressure drops below a predetermined level. Warning light on dash indicates an energized emergency power steering system. Rear wheel steer alignment indicator provided.

SERVICE BRAKES — Full air on all four wheels. Size 28 in. x 8 in. (711mm x 203mm) with a total lining area of 896 sq. in. (5781cm²). Air dryer prevents moisture in the system for maximum braking efficiency. Equipped with a dual brake system for emergency backup air.

PARKING BRAKES — Spring-set emergency/parking brakes on all four wheels.

TIRES — 33.25 x 35 — 32 PR (E-3) Earthmover type, tubeless.

***TOW WINCH** — Braden PD15 cab-controlled, tow winch (less rope and hook), front mounted. Single line pull — 15,000 lbs. (6804kg); single line speed — 58.9FPM (17.9m/min.). Drum rope storage capacity of 340 ft. (103.6m) of ⅝ in. dia. (16mm) rope.

HYDRAULIC SYSTEM:

RESERVOIR: 375 gallon (1419 liter) capacity, all-steel fabrication with internal baffles, clean-out access, exterior oil sight level gauge. Strap-mounted to frame to reduce high stress levels at corner welds. In-tank hydraulic oil temperature gauge.

FILTER — Tank mounted, return line replaceable cartridge with bypass protection and filter bypass indicator. 25 micron rating.

PUMPS — Two triple main gear pumps, (6 sections) 317 GPM (1120 LPM) combined capacity. Power steering pump 37 GPM (140 LPM) capacity. Pump disconnects for both main pumps are spring loaded to facilitate ease of engagement.

CONTROL VALVES — Precision four-way double-acting with integral load holding, main and circuit relief valves. Six individual valve banks permitting simultaneous independent control. Maximum operating pressure 2500 PSI (175.8kg/cm²).

OIL COOLER — Turntable-mounted, full flow, oil to air with thermally controlled hydraulic motor driven fan.

POWER DISTRIBUTION — Main hoist, auxiliary hoist boost — 51 GPM (193 LPM) @ 2500 psi (175.8kg/cm²); main hoist boost, auxiliary hoist, lift boost, inner mid telescope — 51 GPM (193 LPM) @ 2500 psi (175.8kg/cm²); lift — 51 GPM (193 LPM) @ 2500 psi (175.8kg/cm²); rear steer, outer mid telescope — 51 GPM (193 LPM) @ 2500 psi (175.8kg/cm²), fly telescope - 51 GPM (193 LPM) @ 2500 psi (175.8kg/cm²), swing, outriggers — 25 GPM (94.6 LPM) @ 2250 psi (158.1kg/cm²).

MISCELLANEOUS STANDARD EQUIPMENT — Complete light package, tool box and storage compartment, fenders, hook-block tie-down, combination lifting lugs, tow loops and tie-down attachments, front and rear pintle hook mounting brackets (less pintle hooks), ether injection cold start aid (less canister), engine air cleaner restriction indicator, audio-visual low boom angle swing alarm system, rear view mirrors, storage installation for removable windshield, hydraulic test panel, 3¾ lb. (1.7kg) dry type fire extinguisher, tire inflation kit.

MISCELLANEOUS OPTIONAL EQUIPMENT — Automatic, backup alarm, front and/or rear pintle hooks, hoist drum cable followers, pick and carry counterweight package.

**Denotes optional equipment*

ENGINE SPECIFICATIONS

MAKE & MODEL	Detroit Diesel 6-71T	*Cummins NT-855	*Caterpillar 3306TA
TYPE	6 cylinder O.H.V.	6 cylinder O.H.V.	6 cylinder O.H.V.
BORE	4.25 in. (108mm)	5.5 in (140mm)	4.75 in. (121mm)
STROKE	5 in. (127mm)	6 in. (152mm)	6 in. (152mm)
DISPLACEMENT	426 cu. in. (6982cm ³)	855 cu. in. (14010cm ³)	638 cu. in. (10 454cm ³)
HORSEPOWER (NET)	230	219	230
GOVERNED RPM	2100	2100	2100
TORQUE (NET)	672 ft. lb. (92.9kg.m) @ 1600	696 ft. lb. (96.2kg.m) @ 1500	667 ft. lb. (92.2kg.m) @ 1450
ELECTRICAL SYSTEM	12 volt, neg. grd.	12 volt, neg. grd.	12 volt, neg. grd.
STARTING SYSTEM	24 volt	24 volt	24 volt
COMBUSTION SYSTEM	2 cycle w/blower and turbo-charger	4 cycle w/turbo-charger	4 cycle w/turbo-charger and aftercooler
COOLING SYSTEM (CAP.)	Liquid - 14.5 gal. (54.9 liters)	Liquid - 14 gal. (53 liters)	Liquid - 14.25 gal. (53.9 liters)
FUEL CAPACITY	100 gallons (379 liters)	100 gallons (379 liters)	100 gallons (379 liters)
ALTERNATOR	90 AMP	90 AMP	90 AMP
BATTERY	•(4) 475 CCA @ 0°F	•(4) 475 CCA @ 0°F	•(4) 475 CCA @ 0°F
AIR CLEANER	Dry type	Dry type	Dry type
AIR COMPRESSOR	12 CFM	13.2 CFM	12 CFM
HOURMETER	Standard	Standard	Standard

•CCA = cold cranking amperage

*Denotes optional equipment

AXLE WEIGHT DISTRIBUTION CHART

ITEM	POUNDS			KILOGRAMS		
	GROSS	FRONT	REAR	GROSS	FRONT	REAR
Basic standard machine to include: 36 ft. - 114 ft. (11.0m - 34.6m) 4-section Trapezoidal main boom, 32 ft. (9.8m) Swingaway section, HO30B-26 main hoist with 750 ft. (228.6m) of 3/4 in. (19mm) dia. rope, HO30B-16 auxiliary hoist with *550 ft. (167.6m) of 3/4 in. (19mm) dia. rope, Detroit diesel 6-71T engine, •15,103 lbs. (6851kg) counterweight, 33.25x35-32 P.R. tires	131,729	61,982	69,747	59,752	28,115	31,637
ADD:						
Auxiliary boom nose	+220	+552	-332	+100	+250	-150
28 ft. (8.5m) A-frame jib (stowed)	+1,582	+1,739	-157	+718	+789	-71
80 ton (73mt) hook block	+1,970	+4,731	-2,761	+894	+2146	-1252
Braden front mounted tow winch	+936	+1,390	-454	+425	+631	-206
20,000 lbs. (9,072kg) frame-mounted counterweight	+20,000	-10,810	+30,810	+9072	-4903	+13 975
Brackets for frame-mounted counterweight	+1,025	-462	+1,487	+465	-210	+675
Front carry deck	+1,365	+1,586	-221	+619	+719	-100
SUBSTITUTE:						
••• Gearmatic Model 23 MGEER auxiliary hoist with 550 ft. (167.6m) of 5/8 in. (16mm) dia. rope	-686	+254	-940	-311	+115	-426
••• 15,513 lbs. (7037kg) counterweight	+410	-151	+561	+186	-68	+254
•• 16,863 lbs. (7649kg) counterweight	+1,760	-647	+2,407	+798	-294	+1092
Cummins NT-855 engine	+546	-73	+619	+248	-33	+281
Caterpillar 3306TA engine	-	-36	+36	-	-16	+16
REMOVE:						
• HO30B-16 auxiliary hoist with 550 ft. (167.6m) of 3/4 in. (19mm) dia. rope	-2,437	+902	-3,339	-1105	+410	-1515
32 ft. (9.8m) Swingaway section	-2,465	-3,467	+1,002	-1118	-1573	+455
36 ft. - 114 ft. (11.0m - 34.6m) 4-section boom	-24,510	-28,965	+4,455	-11 118	-13 139	+2021
36 ft. - 114 ft. (11.0m - 34.6m) 4-section boom and lift cylinders	-28,575	-32,435	+3,860	-12 962	-14 713	+1751
Tires and wheels	-11,900	-5,950	-5,950	-5398	-2699	-2699
Outrigger beams and jacks (front)	-4,360	-5,963	+1,603	-1978	-2705	+727
Outrigger beams and jacks (rear)	-4,360	+1,603	-5,963	-1978	+727	-2705
• 15,103 lbs. (6851kg) counterweight	-15,103	+5,551	-20,654	-6851	+2518	-9369

NOTE: Appropriate counterweight substitutions must be made depending on main and auxiliary hoist configuration specified.

- 15,103 lbs. (6851kg) counterweight used with HO30B-26 main hoist and HO30B-16 auxiliary hoist.
- 16,863 lbs. (7649kg) counterweight used with HO30B-26 main hoist only.
- 15,513 lbs. (7037kg) counterweight used with HO30B-26 main hoist and model 23 MGEER auxiliary hoist.

A RUGGED FRAME FOR A BIG LIFTER

The outstanding performance of the RT980 begins with the high-strength steel, double parallel box beam frame construction with boxed cross-members to the rear and triple box construction to the front. The entire frame is welded as a single unit, reinforced at critical points to resist torsional stresses and provide a strong, rigid lifting base. After assembly, the bearing mounting surface is precision machined to prevent distortion of the swing circle. Outrigger boxes are integral with the frame to provide additional strength and stability.

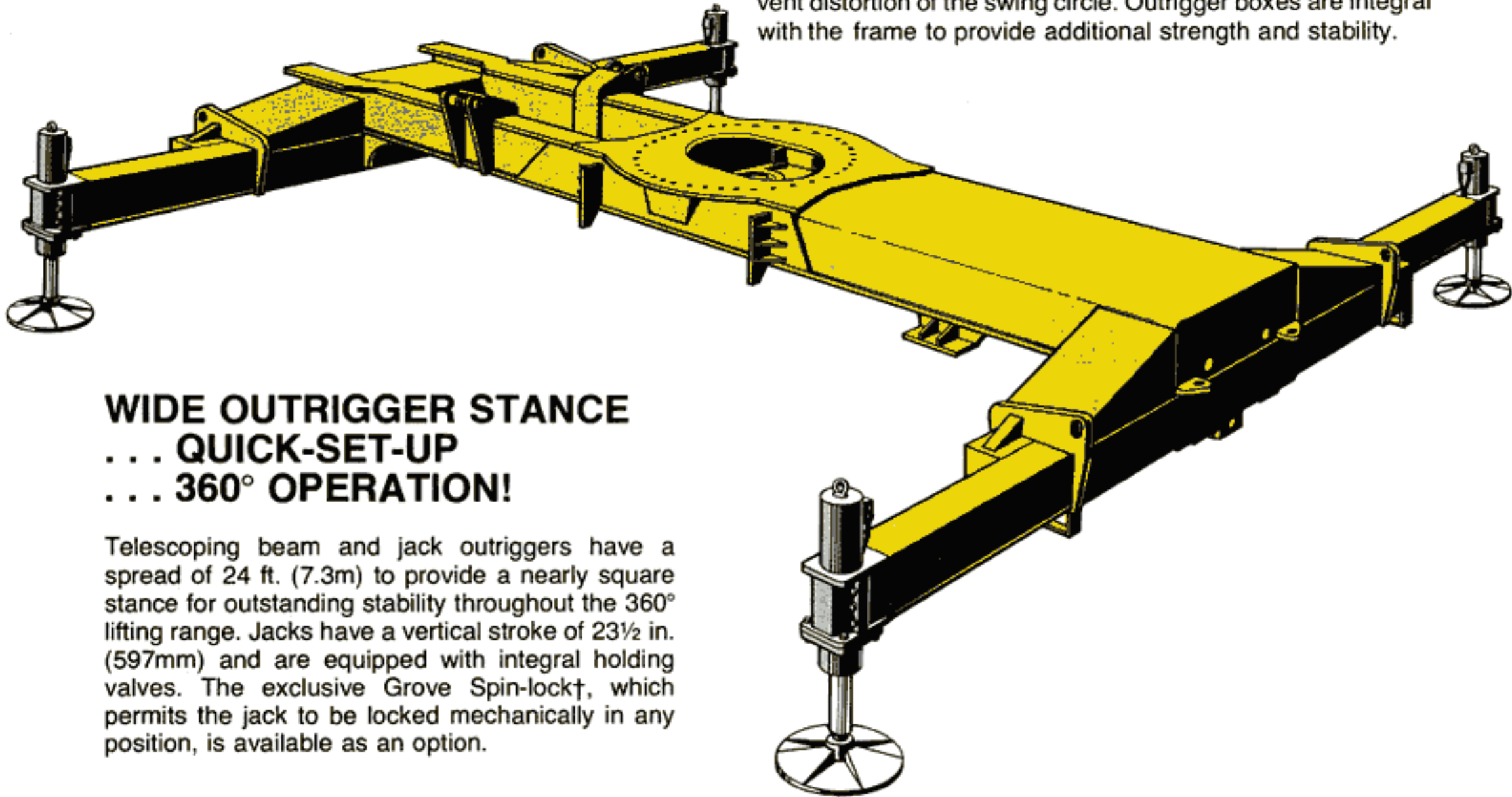

WIDE OUTRIGGER STANCE ... QUICK-SET-UP ... 360° OPERATION!

Telescoping beam and jack outriggers have a spread of 24 ft. (7.3m) to provide a nearly square stance for outstanding stability throughout the 360° lifting range. Jacks have a vertical stroke of 23½ in. (597mm) and are equipped with integral holding valves. The exclusive Grove Spin-lock†, which permits the jack to be locked mechanically in any position, is available as an option.

EASY MANEUVERABILITY

Full-power hydraulic steering with 4-steering modes permits 4-wheel coordinated, 4-wheel crabbing, 2-wheel (front or rear) steering for easier maneuvering in tight quarters. Grove's system of independent control for each axle permits a greater degree of maneuverability with greater ease for the operator.

